

# GO REGULATOR

## PR-7LF Series

High Sensitivity Pressure Reducing Regulator



The PR-7LF Series pressure reducing regulator is designed to furnish precise low outlet pressure control to analytical instrumentation. With the combination of the large diaphragm sensing area of the PR-7 Series regulator and the low flow seat assembly of the PR-1 Series pressure regulator, pressure control down to 10 inches of water is easily obtainable.

The PR-7LF Series of regulators are available in a choice of stainless steel or brass construction; special alloys are available on special request.

### Features & Specifications

- Sensitive pressure control
- Low pressure adjustability
- Stainless steel or brass construction (optional Monel® or Hastelloy® C construction)
- 20 micron inlet filter
- Optional special fittings including VCR®-compatible face seal (male or female)
- Inlet pressure to 3600 psig
- Adjustable outlet pressure ranges 0-6, 0-25, 0-50, 0-75, 0-125 & 0-250 psig
- Cv flow coefficients of 0.025; 0.06; 0.20; 0.50
- Teflon®/Viton® diaphragm standard up to 25 psig
- 316L stainless steel or brass, Inconel®, Tefzel® & Teflon® in the flow stream
- Operating temperatures -40° F to +250° F (-40° C to +121° C)
- Inlet and outlet connections ¼" FNPT standard

pressure regulators

### GO Regulator

405 Centura Court • PO Box 4866 • Spartanburg, SC 29303  
Phone (864) 574-7966 Fax (864) 574-5608  
www.goreg.com • sales@goreg.com

# PR-7LF Series

## How to Order

### PR7L -

#### BODY MATERIAL

- 1 316L stainless steel
- 2 Brass
- 4 Monel®
- 6 Hastelloy® C

#### PORT CONFIGURATION

- A Standard

For more port configurations, see page 35.

#### PROCESS PORT TYPES

##### (GAUGE PORT TYPES, IF SPECIFIED)

- 1 ¼" FNPT (¼" FNPT gauge ports)
- 4 ⅜" FNPT (¼" FNPT gauge ports)
- 5 ½" FNPT (¼" FNPT gauge ports)
- J ½" Tri-clover (¼" FNPT gauge ports)

#### SURFACE FINISH OF DIAPHRAGM CAVITY

- 1 < 25 Ra

#### SEAT MATERIAL

- A Tefzel®
- D Viton® (0.2 Cv only)
- H PCTFE (formerly Kel-F® 81)
- I High density Teflon®
- K Kalrez® (0.2 Cv only)

#### FLOW COEFFICIENT (Cv)

- 3 0.06
- 5 0.2
- C 0.025
- H 0.5

#### CAP ASSEMBLY

- 1 Standard, stainless steel
- 2 T-handle, stainless steel
- 3 T-handle, panel mount, stainless steel
- 4 Panel mount, stainless steel
- 5 Captured vent, aluminum
- 6 Captured vent, panel mount, aluminum
- 7 Captured vent, stainless steel
- 8 Tamper-proof, stainless steel
- 9 Fine adjust, ½" panel mount, stainless steel
- 0 Fine adjust, 1⅜" panel mount, stainless steel
- C Captured vent, panel mount, stainless steel
- E Tamper-proof, panel mount, stainless steel
- H ¼" NPT, dome-loaded

#### DIAPHRAGM FACING/BACKING MATERIAL

- 1 Teflon®/stainless steel
- 2 Teflon®/Viton®
- 5 Viton®/stainless steel
- 6 Tefzel® ring/stainless steel
- 7 Tefzel® ring/Hastelloy® C
- 8 Teflon®/Inconel®
- 0 Teflon®/Hastelloy® C

#### DIAPHRAGM TYPE

- 1 Standard diaphragm
- 2 Diaphragm-attached poppet
- 3 Self-relieving

#### OUTLET RANGE

- B 0-6 psig
- D 0-25 psig
- E 0-50 psig
- F 0-75 psig
- H 0-125 psig
- I 0-250 psig

*NOTE: The choices above represent an abbreviated list of the more commonly ordered options. For a complete listing of all available options, please see the Selection Wizard on the GO website at [www.goreg.com](http://www.goreg.com) or contact the factory.*

## Maximum Temperature & Operating Inlet Pressures

| SEAT MATERIAL              | MAXIMUM TEMPERATURE* | @ | MAXIMUM OPERATING INLET PRESSURE |
|----------------------------|----------------------|---|----------------------------------|
| Teflon®                    | 150° F (66° C)       | @ | 3600 psig (24.82 MPa)            |
| Tefzel®                    | 150° F (66° C)       | @ | 3600 psig (24.82 MPa)            |
| PCTFE (formerly Kel-F® 81) | 175° F (80° C)       | @ | 3600 psig (24.82 MPa)            |
| Viton®                     | 250° F (121° C)      | @ | 300 psig (2.07 MPa)              |
| Kalrez®                    | 250° F (121° C)      | @ | 300 psig (2.07 MPa)              |

\* Temperatures in excess of 175° F (80° C) require a metal knob or the tamper-proof option.

Inconel® and Monel® are registered trademarks of Special Metals Corporation.  
Hastelloy® is a registered trademark of Haynes International, Inc.  
VCR® is a registered trademark of Cajon Co.  
Teflon® and Tefzel® are registered trademarks of the DuPont Company.  
Kalrez® and Viton® are registered trademarks of DuPont Dow Elastomers.

## Outline and Mounting Dimensions

Weight = 3.2 lbs (1.45kg)

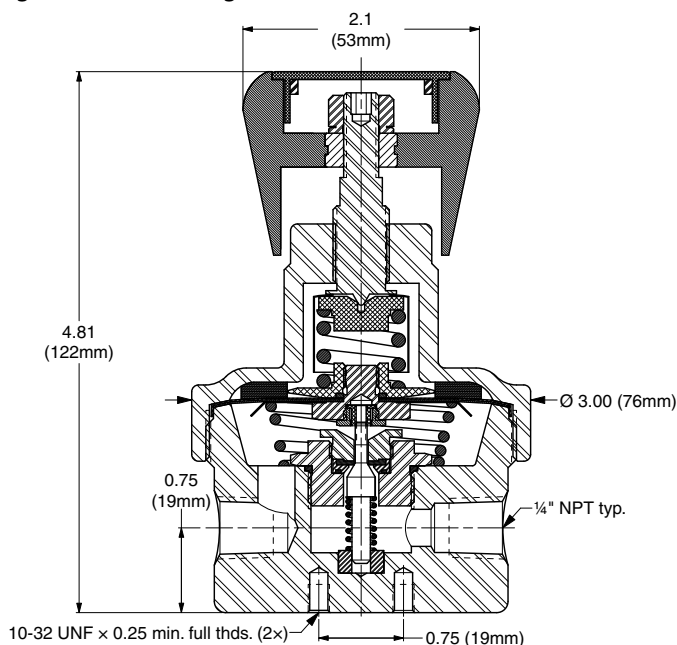

# Porting Configurations for Single Stage Pressure Regulators

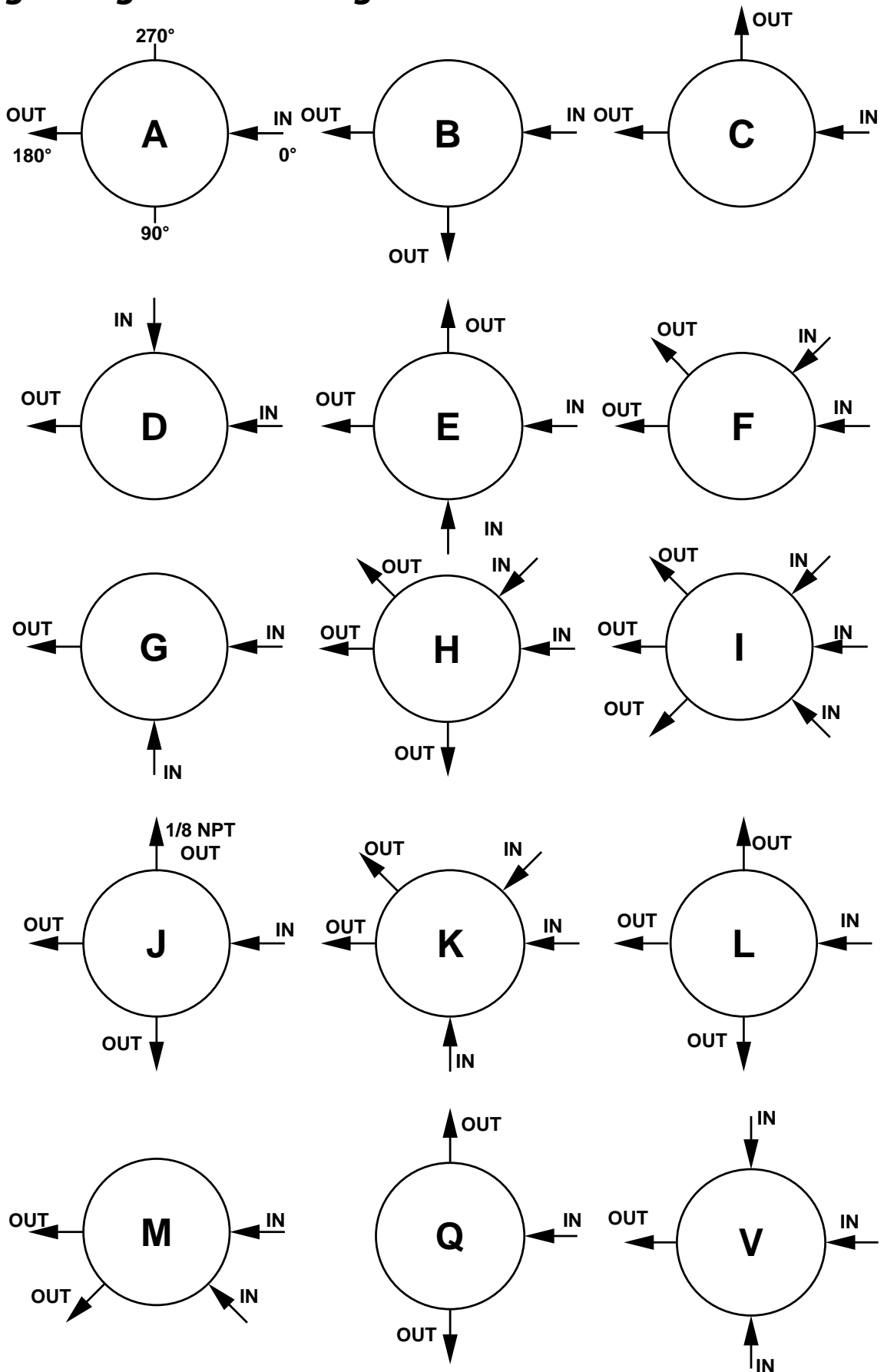

LOCATION OF PORTS FROM  
TOP VIEW